

QUARTZ TIME RECORDER

Simplex 500

OPERATION MANUAL

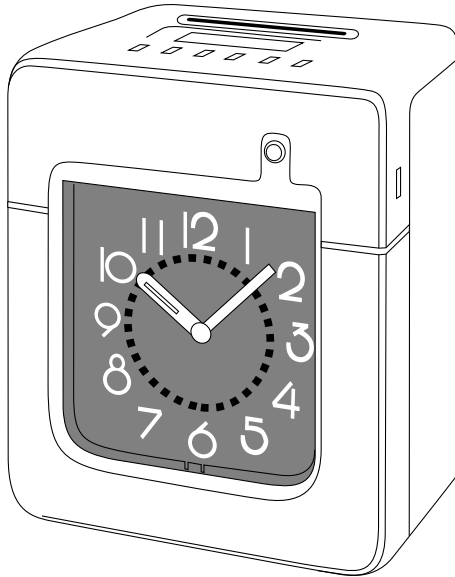

 **Simplex**

Bescheinigung des Herstellers/Importeurs

Dies Gerät entspricht den Bedingungen der Niederspannungs-Vorschrift 73/23/EEC und dem EMVG nach 89/336/EEC.

This unit complies with the Low Voltage Directive 73/23/EEC and the EMC Directive 89/336/EEC.

Maschinenl ärminformationsverordnung 3. GSGV, 18.01.1991:
Der arbeitsplatzbezogene Schalldruckpegel beträgt 70 dB (A) oder weniger gemäß ISO 7779.

Die zugehörige Steckdose muß nahe beim Gerät angebracht und leicht zugänglich sein.

1. The details of this Operation Manual are subject to change without previous notification.
2. This Operation Manual has been prepared with the utmost care to cover all aspects of the time recorder's use.
If you feel, however, that some explanations are inadequate, unclear, or difficult to understand, please do not hesitate to contact the dealer or the shop from which you have purchased your Time Recorder.
3. Be sure to use your Time Recorder after you have fully understood the hardware and software specifications and limits.
4. No part of this publication may be reproduced, stored in a retrieval system, or transmitted, in any form or by any means, mechanical, photocopying, recording or otherwise.
 - Replace battery with TOSHIBA, part no. CR 2450 THC only.
Use of another battery may present a risk of fire on explosion.
 - Place the time recorder close to the wall outlet so that it is easily accessible to disconnect.

TABLE OF CONTENTS



1. PRECAUTIONS	1
2. FEATURES	3
3. BEFORE USING THE TIME RECORDER	4
Accessories	4
Features	4
Installing the Ribbon Cassette	5
Wall Mounting	6
Environmental Conditions	6
4. DAILY OPERATIONS	7
5. SETTING	8
Preparation for setting	8
Setting the Pay Period	9
Setting the Date and the Time, 1/60 or 1/100 printing, and the 12/24 HOUR format	12
Setting the Day Advance Time	14
Setting the Daylight Saving Time (D.S.T.)	15
Setting the Time Table Program	18
Setting Number of Seconds for External Time Signal	25
Resetting	26
6. CONNECTING TO AN EXTERNAL TIME SIGNAL	27
7. INSERTING THE Ni-Cd BATTERY	28
8. TROUBLESHOOTING	29
9. SPECIFICATIONS	30
10. TIME CARD SPECIFICATIONS	31





1. PRECAUTIONS







This operation manual is prepared for safe and proper use of the unit. Please follow all the instructions to avoid possible danger to yourself or others and damage to the unit.

Signs

Various warnings and cautions are provided throughout this manual along with signs. Remember each sign and its explanation listed below for your safety and proper operation of the unit.

	Warning	Improper handling may cause bodily accidents including death and serious injury.
	Caution	Improper handling may harm the human body or material.

	Improper handling may cause electric shock DANGER.		"Must-Do" sign.
	DO NOT disassemble the unit.		Be sure to remove the line cord plug from the outlet.
	"Don't" sign.		

		Warning
	Do not disassemble the unit. There is a high voltage present inside, possibly leading to an electric shock.	
	Do not modify the unit. Modifications may cause a fire and/or electric shock.	
	If any anomaly occurs, for example, heat or smoke is generated or an odor is emitted, unplug the unit immediately and contact your dealer for servicing. There is a danger that further use may cause a fire or electric shock.	
	Do not use any voltage of the power source other than designated. Do not share a single outlet with another plug. These may lead to fire or shock hazards.	
	Do not damage, break, or modify the power cord. Do not put a heavy object on, pull, or forcefully bend the cord, either. These may damage the cord, possibly resulting in a fire or electric shock.	

2. FEATURES

- The time table program provides the following functions:
 - Automatic switching between black and red printing
The two-color printing system makes it possible to easily see an employee's in and out time.
 - Automatic activation of an external time signal
The unit can be programmed to externally output a signal when it's time to start or quit, or for breaks.
 - Automatic switching among six print columns (Columns 1-6)
The auto-switching function of a column to print records in prevents punching failure or error.
- It has three selectable pay periods : weekly, bi-weekly or monthly.
- The monthly card automatically senses the front or back of the card, therefore assuring no erroneous date printing.
- If the closing date for payroll processing does not fall on the end of a month, the unit can be set to any desired closing date.
- The day advance time function makes it possible to print out on the same line of a time card for the previous working day even when leaving the office after midnight.
- An easy-to-see analog clock is provided on its front for users' convenience.
- User-friendly operation and easy setting enhance users' comfort.

3. BEFORE USING THE TIME RECORDER

Accessories

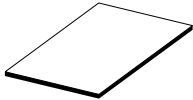

Operation Manual

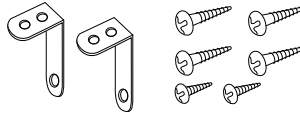

Wall mount fittings

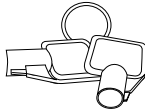

Keys

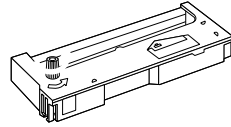

Ribbon cassette

Features

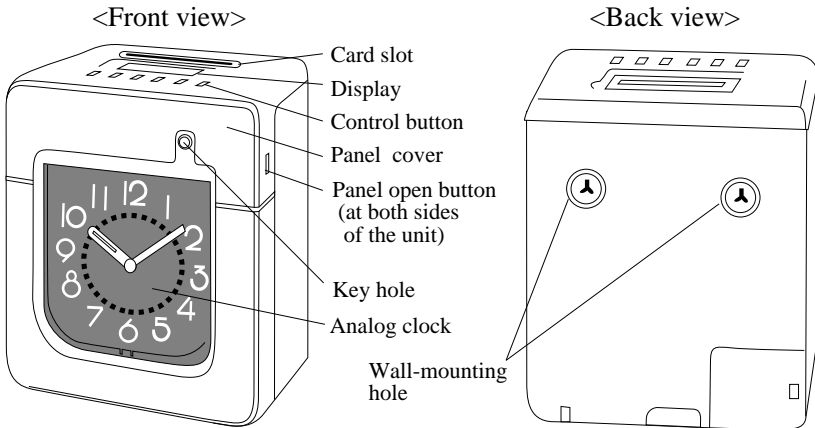

<Display>

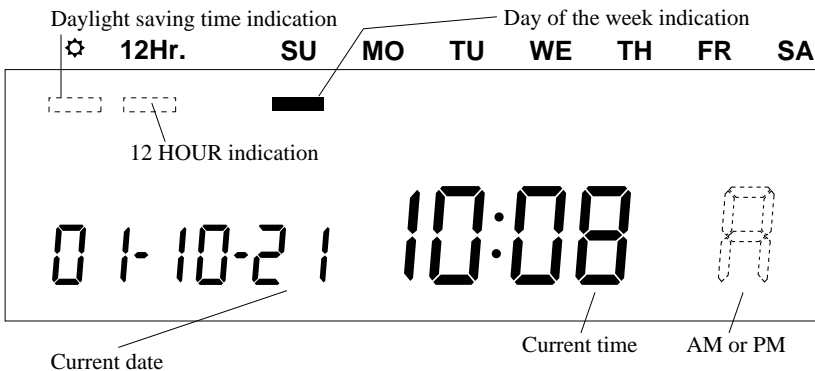

Installing the Ribbon Cassette

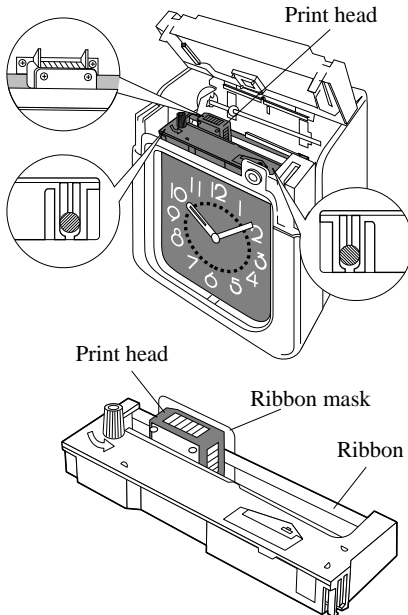
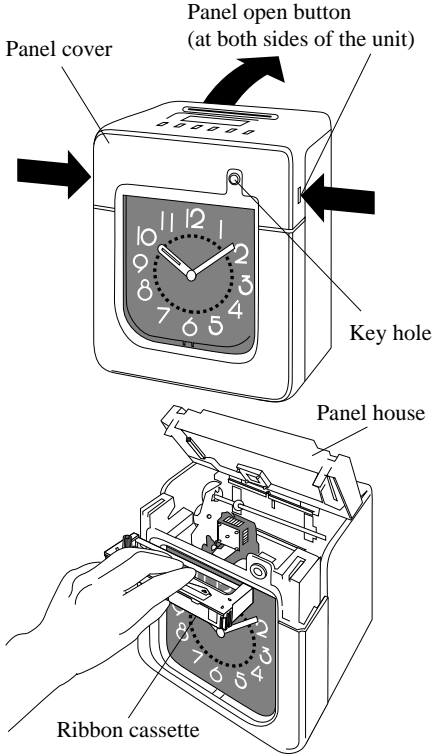

1 Unlock the unit. While holding down the panel, open buttons at both sides of the unit, and lift the panel cover away from you.

2 Turn the knob on the cassette in the arrow-indicated direction to make the ribbon taut.

To insert the ribbon cassette inside the unit, lift the panel house away from you first. Then thread the ribbon between the ribbon mask and the print head. Slide the latch on the lower side of the cassette into projections on the unit. Then let the cassette snap into place.

When having difficulty inserting the ribbon, insert it while turning the knob.

Make sure that the ribbon is placed between the print head and the ribbon mask as illustrated in the figure at left.

3 Put the panel cover on the hook at the back of the unit. Lower it toward this side to close and lock the unit.

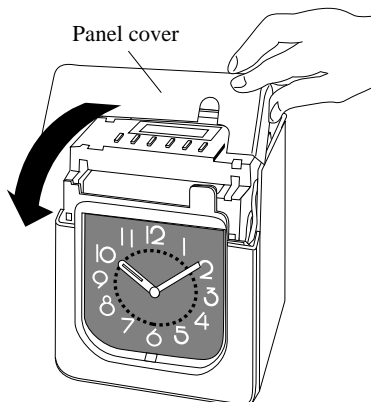

Wall Mounting

The unit can be mounted on a wall using the supplied mounting fittings. To mount the unit on a wall, take the following steps:

1 Install the two larger screws into a wall 3.94 inches (10 cm) apart. Be sure to keep about 0.12 inch (3 mm) of the screw head out of the wall.



The supplied screws are intended for use on a thick wooden wall or wooden column. Do not use them on any other materials. There is a danger that the unit may come off.

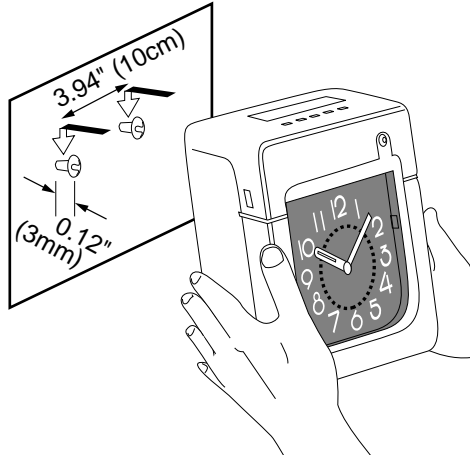

2 Mount the wall mount fittings as shown on the right.

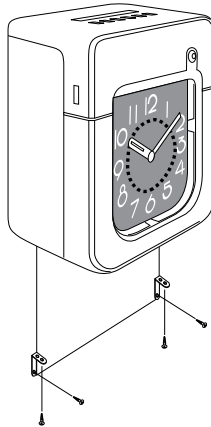

Environmental Conditions

Avoid placing the unit in environments that are:

- humid or dusty
- exposed to direct sunshine
- subject to frequent or continuous vibrations
- outside the temperature range between -5° and 45°C
- affected by chemicals or ozone

4. DAILY OPERATIONS

Once the AC line cord is plugged into the outlet, the unit can be used immediately as basic operation has been pre-set at the factory, including the time and the closing date.



See "3 BEFORE USING THE TIME RECORDER".

It is easy to operate the unit. Just insert a time card. The card is then automatically pulled in, printed and then ejected.



Do not let any metallic object get into the slot, including paper clips. Do not forcefully push in a card, either. These may cause the unit to malfunction.

If any setting needs to be changed, such as for a closing date or other items, See "5. SETTING".

The unit is designed to print in black on the first column when no time table program is set. Usually it is necessary to set the time table program in order to automatically print colors and to change columns to print records in. For a temporary change of a column, however, manual operation is also available: just push the button for any desired column before inserting a time card.

The button for the column selected lights up.

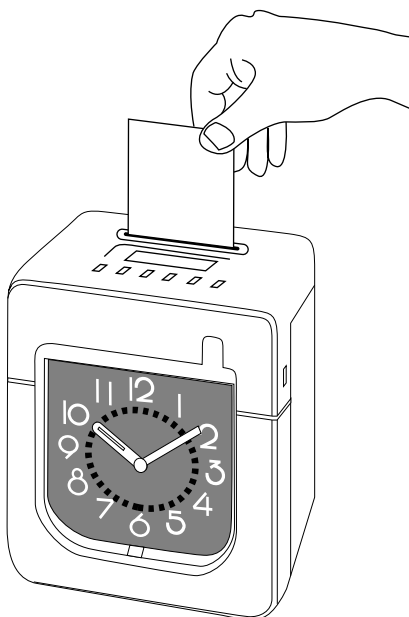

5. SETTING

Preparation for setting

To prepare for setting:

- 1 Unlock the unit. While holding down the panel, open buttons at both sides of the unit and lift the panel cover away from you.
- 2 Remove the panel cover.

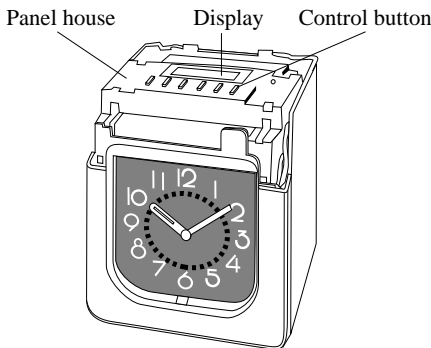
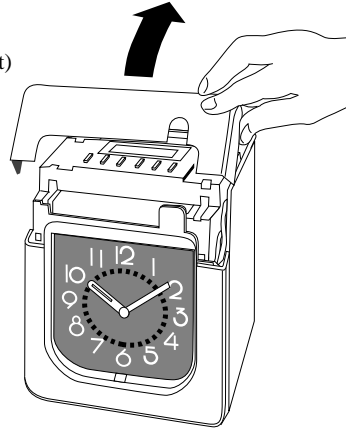
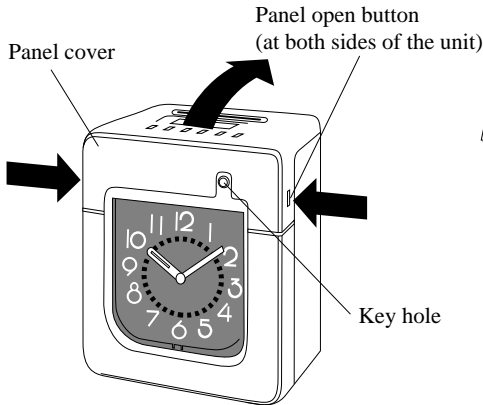

- 3 Make settings using the display and control buttons at the panel house.



Be sure to make settings with the power on.

Upon opening the panel cover, the **PAY ENDING** button lights up and the unit is in the pay ending setting mode.

Make sure to press **SET** at the completion of each setting. Contents are NOT stored in memory if **SET** is not pressed.

Setting the Pay Period

- The closing date is factory-set at the end of a month (31st).
- The **PAY ENDING** button stays lit up during its setting operation.

Monthly Closing

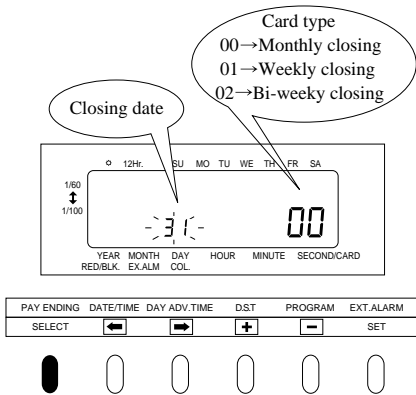

1 Remove the panel cover.
Make sure that **PAY ENDING** stays lit up.

2 The closing date is shown at the left on the display, and the card type at the right.
The card type for monthly closing is "00".

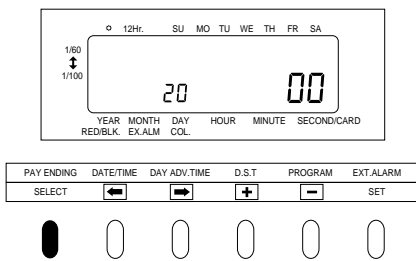

3 **+** or **-** to select date desired.
Example: If closing date is the 20th every month, set the digits on the left at "20".

Always select the 31st in the case of month-end closing, which is normally factory-set unless you change the setting.

4 Check the settings on the display and press **SET**.

Weekly Closing

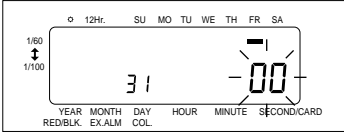

PAY ENDING	DATE/TIME	DAY ADV.TIME	D.S.T	PROGRAM	EXT.ALARM
SELECT	←	→	+	-	SET

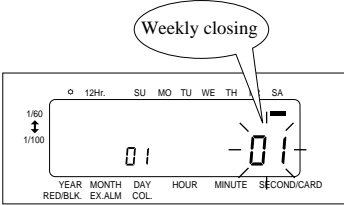

PAY ENDING	DATE/TIME	DAY ADV.TIME	D.S.T	PROGRAM	EXT.ALARM
SELECT	←	→	+	-	SET



Today is printed on the second line from the top.

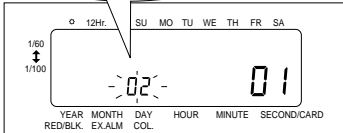

PAY ENDING	DATE/TIME	DAY ADV.TIME	D.S.T	PROGRAM	EXT.ALARM
SELECT	←	→	+	-	SET



Today	_____	①
Tuesday, January 9, 2001	_____	②
Set closing day	_____	③
Sunday, January 14, 2001	_____	④
	_____	⑤
	_____	⑥
	_____	⑦
	_____	⑧
	_____	⑨
	_____	⑩

1 Remove the panel cover.
Make sure that the **PAY ENDING** button stays lit up.

2 Press **←** or **→** to cause the digits at the right to flash ("00").

3 Press **+** or **-** to select "01".

4 Press **←** or **→** to cause the digits at the left to flash.
Today's printing line can be set at any line from above on the weekly card, by referring to the example below.

Example: Assume that today is Tuesday, January 9, 2001 and the closing date is Sunday. As illustrated in the figure on the left, today's printing line is set at the second line from the top since Sunday becomes the closing date if Sunday, January 14, 2001 is set at the bottom line.

Press **+** to set the right-side number of the display at "02".

5 Check the settings on the display and press **SET**.

Use Weekly Cards for weekly closing. The day of the week and time are recorded on the card.

Bi-Weekly Closing

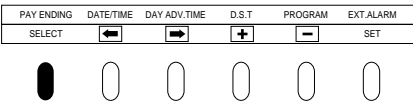
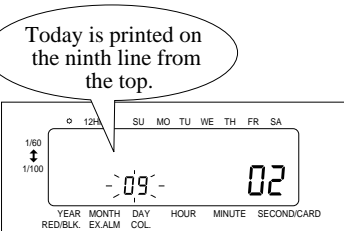
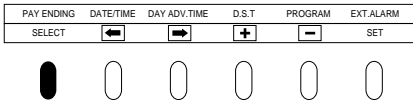
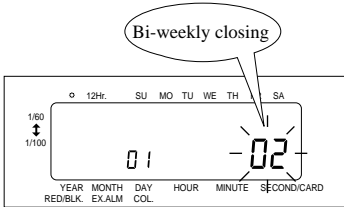
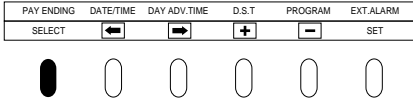
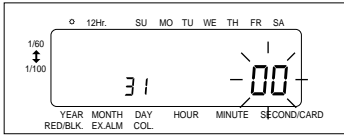

Today
Tuesday, January
9, 2001

Set closing day
Sunday, January
14, 2001

	IN	OUT	IN	OUT	IN	OUT
1						
2						
3						
4						
5						
6						
7						
8						
9						
10						
11						
12						
13						
14						
15						

1 Remove the panel cover.
Make sure that the **PAY ENDING** stays lit up.

2 Press **←** or **→** to cause the digits at the right to flash "00".

3 Press **+** or **-** to select "02".

4 Press **←** or **→** to cause the digits at the left to flash.

Today's printing line can be set at any line from above on the bi-weekly card by referring to the example below.

Example: Assume that today is Tuesday, January 9, 2001 and the closing date is this Sunday, January 14, 2001. Therefore, today corresponds to the second Tuesday of this pay period. As illustrated in the left figure, today's printing line is set at the ninth line from the top if Sunday, January 14, 2001 is set at the bottom line.

Press **+** or **-** to set the right number of the display at "09".

5 Check the settings on the display and press **SET**.

Use bi-weekly cards for bi-weekly closing.
The day of the week and time are recorded on the card.

Setting the Date and the Time, 1/60 or 1/100 printing, and the 12/24 HOUR format

The **DATE/TIME** button stays lit up during its setting operation.

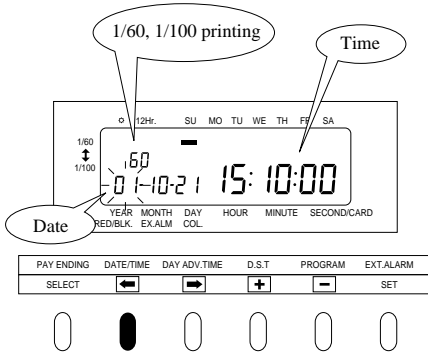

1 Press **SELECT** to illuminate the second button from the left, **DATE/TIME**.

Date is indicated at the left, and time at the right on the display.

To set the number, the digits must flash.

2 To set date

Press **←** or **→** to cause digits to flash and press **+** or **-** to select the desired date.

Example: For October 21, 2001, adjust the digits to "01-10-21".

3 To set time

Press **←** or **→** to cause the digits to flash and press **+** or **-** to select the desired time.

When the hour and minute are entered, the second indication is automatically reset at "00".

How to set 12 hour format

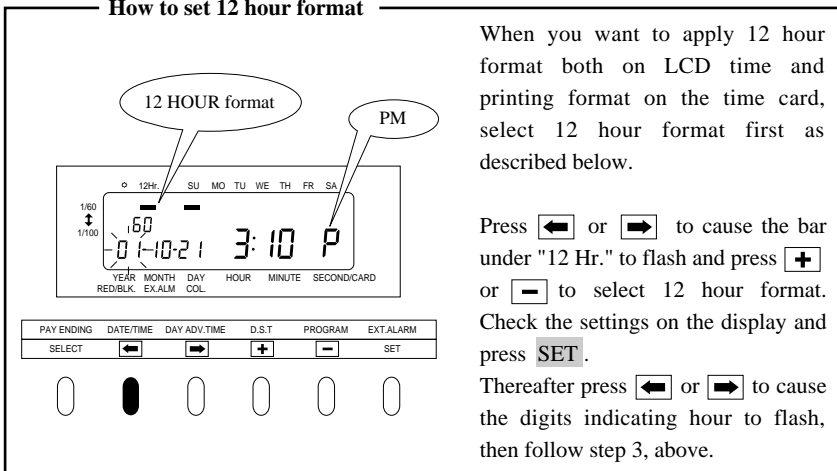

When you want to apply 12 hour format both on LCD time and printing format on the time card, select 12 hour format first as described below.

Press **←** or **→** to cause the bar under "12 Hr." to flash and press **+** or **-** to select 12 hour format. Check the settings on the display and press **SET**.

Thereafter press **←** or **→** to cause the digits indicating hour to flash, then follow step 3, above.

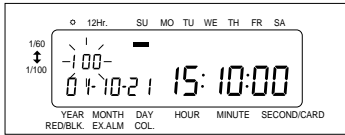

PAY ENDING	DATETIME	DAY ADV.TIME	D.S.T	PROGRAM	EXT.ALARM
SELECT	←	→	+	-	SET



Example of printing:
 In the case of 14:58
 1/60 indication → 14:58
 1/100 indication → 14.98

- 4** Setting for 1/60 or 1/100 printing
 Press **←** or **→** to cause the digits at the upper left to flash.
 Press **+** or **-** to select the printing between 1/60 or 1/100.

- 5** Check the settings on the display and press **SET**.

Setting the Day Advance Time

The day advance time refers to the time when printing shifts to the next line on a time card for the next day. This function, if printed before the set day advance time, enables the time record to print on the same line of the previous working day even if leaving time is after midnight.

- The day advance time is factory-set at 5:00 a.m. (05:00).
- The **DAY ADV. TIME** button stays lit up during its setting operation.

1 Press **SELECT** to cause the third button from the left, **DAY ADV. TIME**, to light up.

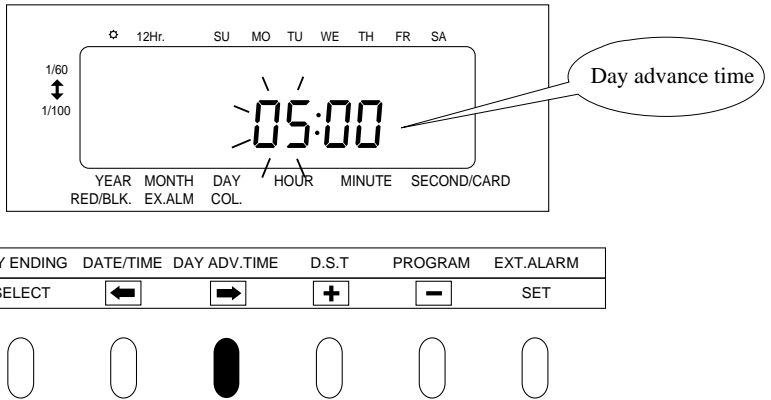

2 Press **←** or **→** to cause digits to flash, and then press **+** or **-** to select the desired time.

Example: If the day advance time is 7:30 a.m., adjust the digits to "07:30".

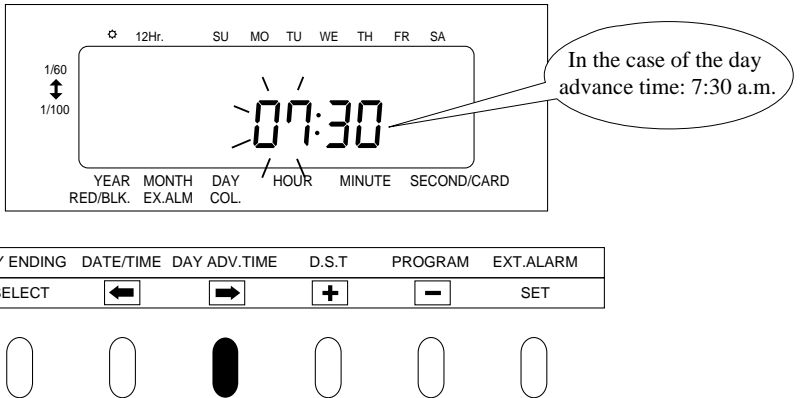

3 Check the settings on the display and press **SET**. Now the setting is completed.

Setting the Daylight Saving Time (D.S.T.)

Daylight saving time function

1 D.S.T. execution time

At 2:00 a.m. on the first day of summer time, the clock automatically gains one hour to show 3:00 a.m. When 3:00 a.m. comes on the last day of the summer time period, it loses one hour and returns to 2:00 a.m.

2 Setting D.S.T.

Example:

Start date Sunday, March 25, 2001

End date Sunday, October 28, 2001

If set as the above, the unit remembers the start date as the last Sunday of March and the end date as the last Sunday of October. Once set, the unit automatically updates the settings every year thereafter. No further manual setting is necessary.

- Daylight saving time is not pre-set at the factory (with the indication of month 00 and day 00).
- The **D.S.T.** button stays lit up during its setting operation.

1 Press **SELECT** to cause the fourth button from the left, **D.S.T.**, to light up.

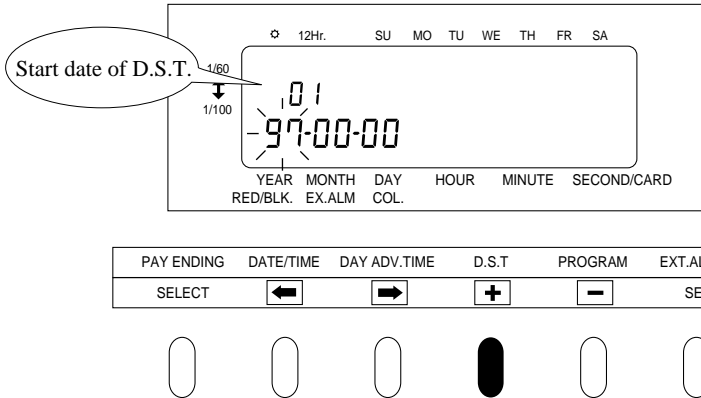

2 Setting the start date

"01" is indicated at the upper left of the display during setting of the start date.

(1) Press **←** or **→** to cause digits to flash, and then press **+** or **-** to select the desired time.

Example: If your D.S.T. starts on March 25, 2001, adjust the digits to "01-03-25".

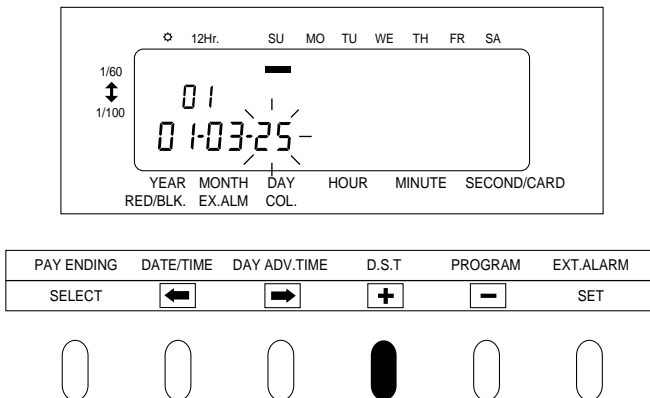

(2) Check the settings on the display and press **SET**. Now the setting is completed.

3 Setting the end date

When the start date setting is completed, the indication at the upper left automatically shifts to "02". You are now in the end date setting mode.

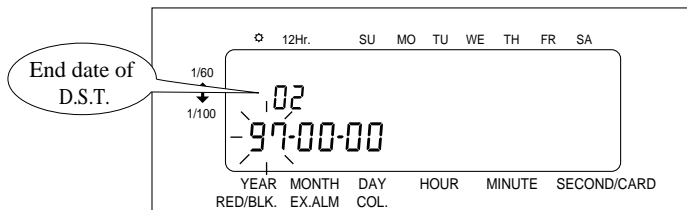

PAY ENDING	DATE/TIME	DAY ADV.TIME	D.S.T	PROGRAM	EXT.ALARM
SELECT	←	→	+	-	SET



(1) Press **←** or **→** to cause digits to flash, and then press **+** or **-** to select the desired time.

Example: If D.S.T ends on October 28, 2001, adjust the digits to "01-10-28".

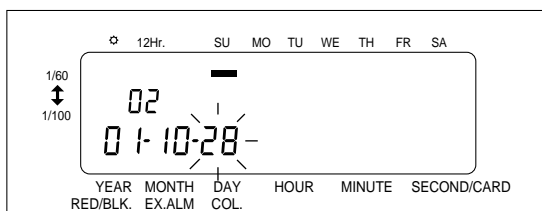

PAY ENDING	DATE/TIME	DAY ADV.TIME	D.S.T	PROGRAM	EXT.ALARM
SELECT	←	→	+	-	SET



(2) Check the settings on the display and press **SET**. Now the setting is completed.

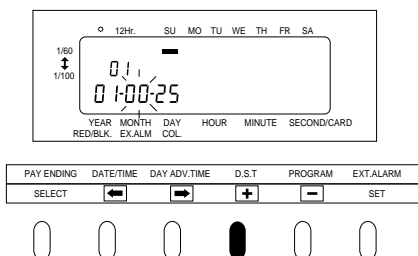

How to Cancel D.S.T. Settings

Place the unit to the D.S.T. start date setting mode as described above (1) and press **←** or **→** to cause month digits to flash. Then select "00" and press **SET** to disable the D.S.T. function.

Setting the Time Table Program

The time table program function allows automatic selection of print color (black or red), an external time signal, and automatic selection of a column to print records in. These functions can be set by the day of the week and time period.

- No time table program is factory-set. (The default is: print in black; no external time signal; and print in Column 1.)
- The **PROGRAM** button stays lit up during its setting operation.

The time table program is explained using the following example.

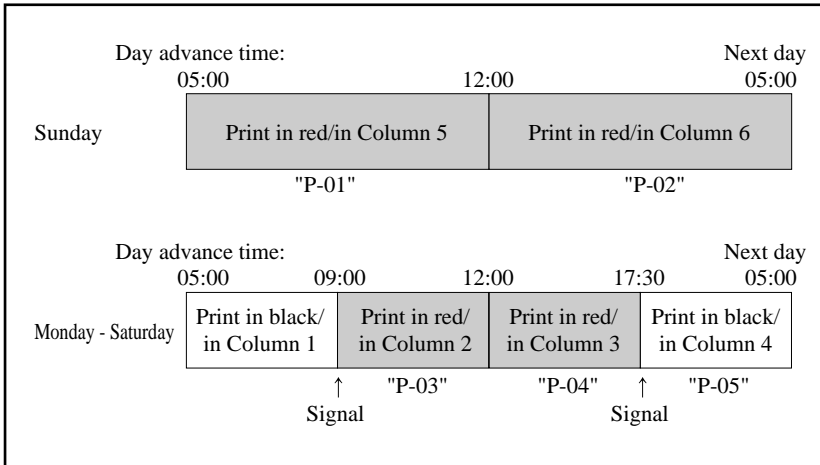

The following is the time table based on the case above.

Program No.	Day of week	Time	Print color	External time signal	Print column
P-01	Sun.	<u>05:00</u>	Red		5
P-02	Sun.	12:00	Red		6
P-03	Mon. - Sat.	09:00	Red	✓	2
P-04	Mon. - Sat.	12:00	Red		3
P-05	Mon. - Sat.	17:30	Black	✓	4

- Times are always printed in black in Column 1 for the time period with no program setting.
- One programmed day begins at the day advance time.
See "Setting Day Advance Time" in this section for details.
- Up to 32 programs can be set (P-01 through P-32).

Follow these steps to set time table programs.

1 Press **SELECT** to cause the **PROGRAM** button light up.

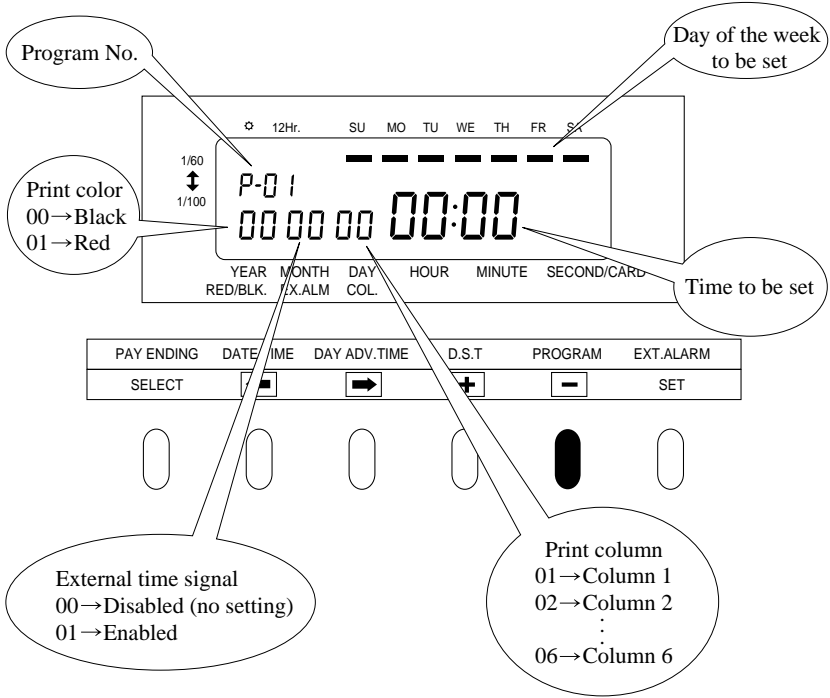

P-01

Print in red

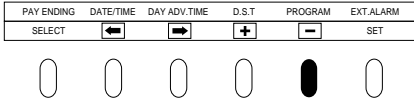
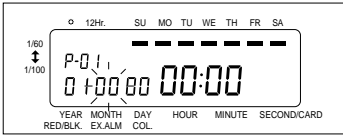
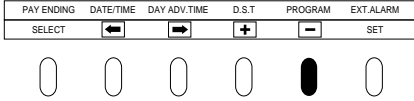

Print in column 5

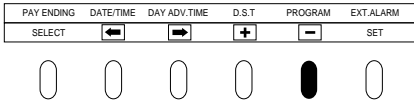
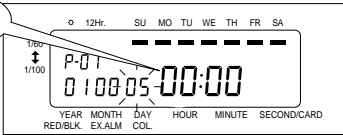

05:00

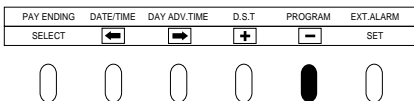
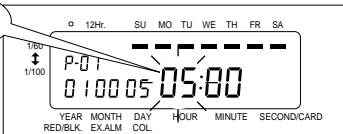

2 To set P-01 (shown in the table above)

(1) Print color

With "P-01" flashing, press once. The print color indication flashes at the lower left of the display. "00" represents "print in black."

Press and change the digits to "01" to be set at "print in red."

(2) External time signal

Press once. The external time signal indication flashes. "00" represents "disabled (no setting)."

Leave the digits as they are since no setting is necessary for the P-01 program.

To enable an external time signal, select "01".

(3) Print column

Press once. The print column indication flashes. "01" represents "Column 1".

Press and change the digits to "05" to set "print in Column 5".

(4) Time

Press the hour indication flashes. Press to change the digits to "05" to set "05:00".

00 minute

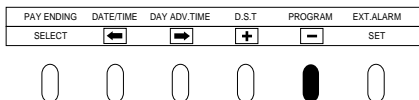
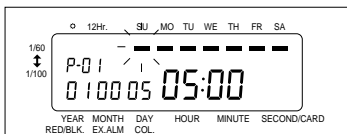
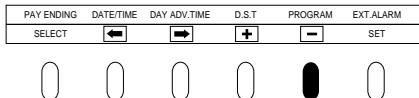
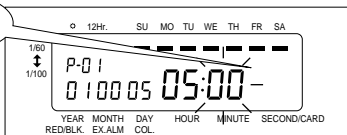

Erase "-"
under MO.

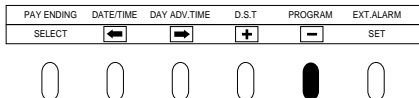
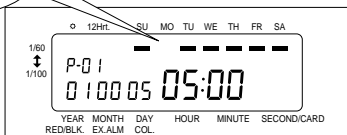

Erase "-"
under TU.

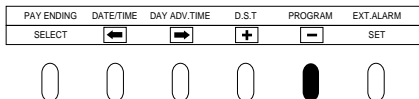
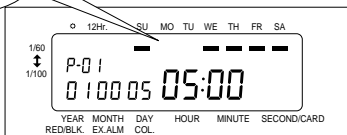

Press again. The minute indication flashes.

Leave the digits as they are since the desired time is 05:00 in this case.

(5)Day of the week

Press . The bar under "SU" flashes ("-").

The factory setting for a day of the week is all days from Sunday through Saturday. If only Sunday needs to be selected, the bars under Monday through Saturday have to be cancelled.

For the P-01 program, to select Sunday only.

First, press to cause the bar under "MO" to flash, and press once to erase the bar ("-").

At that time, the bar under "TU" is already flashing automatically.

Press again to erase the bar ("-").

Erase "-"
under MO - SA.

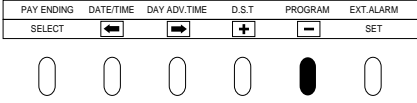
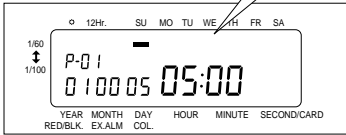

Take the same steps described above to erase the bars for the remaining days of the week.

After erasing the bar under "SA", press **SET**.

Staying lit up

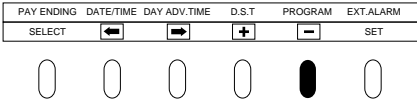

The P-01 indication stays lit up completing the P-01 program setting.

Make sure the bar under any day of the week stays lit up. If the bar does not stay lit up, the time table program will not operate properly.

P-02

Flashing

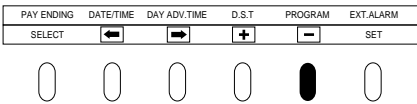
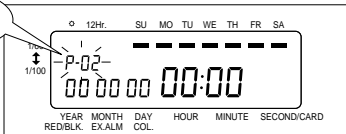

3 To set P-02

After the setting of P-01 is completed, press **+**. The program NO., the indication at the upper left "P-01", flashes. Then press **+P** enter "P-02" setting mode.

The program NO. indication "P-02" flashes.

Staying lit up

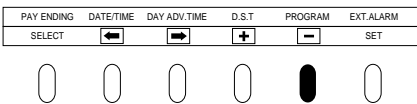
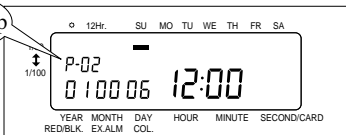

Make settings for P-02 in the same manner as for P-01, as illustrated in the figures at the left.

Press **SET**.

The P-02 indication now stays lit up, showing completion of the P-02 program setting.

Likewise, to shift to P-03, press **+** to cause the P-03 indication to appear flashing.

P-03

External time signal

Make the bars under MO-SA light up

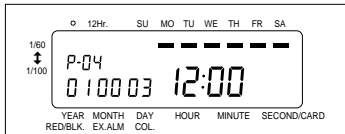

PAY ENDING	DATE/TIME	DAY ADV.TIME	D.S.T	PROGRAM	EXT.ALARM
SELECT	←	→	+	-	SET

**P-04**

PAY ENDING	DATE/TIME	DAY ADV.TIME	D.S.T	PROGRAM	EXT.ALARM
SELECT	←	→	+	-	SET

**P-05**

Print in black

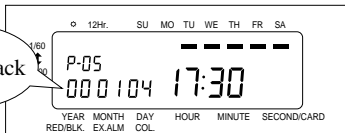

PAY ENDING	DATE/TIME	DAY ADV.TIME	D.S.T	PROGRAM	EXT.ALARM
SELECT	←	→	+	-	SET

**4** To set P-03

Make settings as shown in the figure at left, and press **SET**.

5 To set P-04

Make settings as shown in the figure at left, and press **SET**.

6 To set P-05

Make settings as shown in the figure at left, and press **SET**.
Now the setting of the programs in the table are all complete.

To check program settings

Press **SELECT** to cause **PROGRAM** to light up. Make the desired program No. flash. To see program settings, press **+**.

The **+** button switches among programs in order starting from P-01. Program contents are shown on the display in order starting from Sunday and the line feed time.

To modify program settings

Press **SELECT** to cause **PROGRAM** to light up. Make the desired program No. flash.

Press **←**, **→**, **+**, or **-** to change the settings in the same manner as in its initial setting.

To erase program settings

Press **SELECT** to cause **PROGRAM** to light up. Make the desired program No. flash. The **+** button switches among programs in order starting from P-01. Select the desired program No.

To erase it, set the print column indication at "00" and press **SET**.

Example:

To erase P-04, set the print column indication at "00" and press SET as shown in the figure at left.

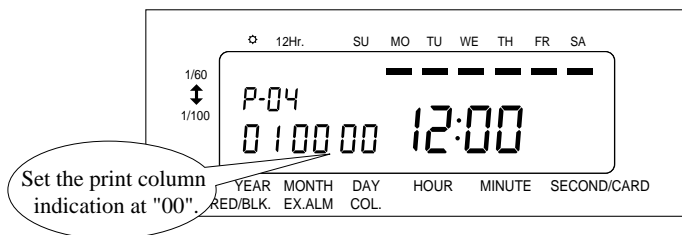

PAY ENDING	DATE/TIME	DAY ADV.TIME	D.S.T	PROGRAM	EXT.ALARM
SELECT	←	→	+	-	SET



Follow the same procedure described above to make settings for the desired program.

Setting Number of Seconds for External Time Signal

This function sets the duration of the external time signal. The setting is enabled only when external time signal is set in the time table program.

- The duration is factory-set at 5 seconds.
- The **EXT. ALARM** button stays lit up during its setting operation.

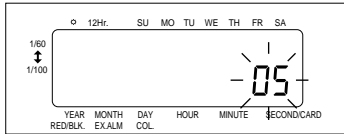

PAY ENDING	DATE/TIME	DAY ADV.TIME	D.S.T	PROGRAM	EXT.ALARM
SELECT	←	→	+	-	SET



1 Press **SELECT** to cause **EXT. ALARM** to light up.

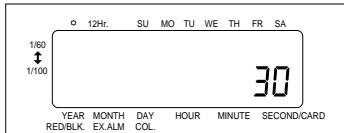

PAY ENDING	DATE/TIME	DAY ADV.TIME	D.S.T	PROGRAM	EXT.ALARM
SELECT	←	→	+	-	SET



2 Press **+** or **-** to adjust the duration in seconds.

Example: To set for 30 seconds, set the second indication at "30".

For the number of seconds, 1 through 30 can be selected

3 Check the settings on the display and press **SET**.

Resetting

To restore all the settings to factory-shipped state, push the reset switch with a pointed object.

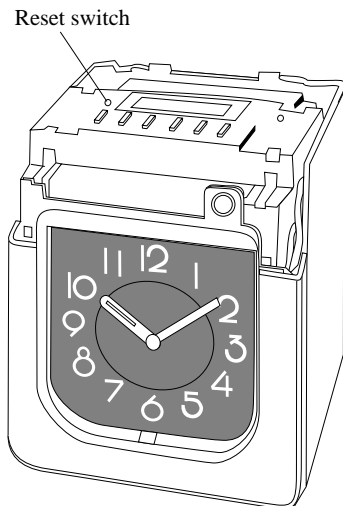

Be careful! Resetting will erase all the settings made by users.
For setting, see "5 Setting".

6. CONNECTING TO AN EXTERNAL TIME SIGNAL

Follow the steps below to connect to an external time signal device.

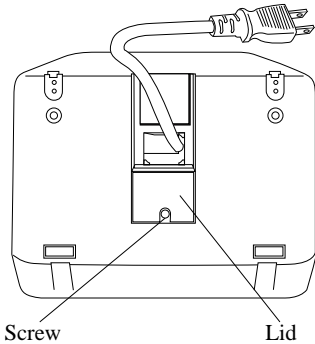

1 Unscrew the screw fixed on the bottom of the unit to remove the lid.

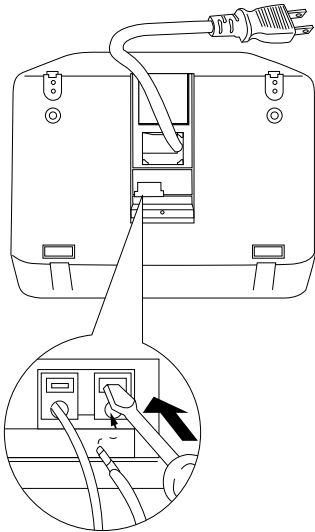

2 Insert two wires for an external time signal while pushing the upper part of the terminal board with a screwdriver.

3 Replace the lid after pulling the wires through the U-shaped cut provided on the lid.

Connection Specifications for External Contact

- Contact output: One circuit, dry contact
- Contact capacity: 5A, 30VDC (Resistive)

7. INSTALLING THE Ni-Cd BATTERY (OPTIONAL)

Follow the steps below to install a Ni-Cd battery (optional) in case of power failure.

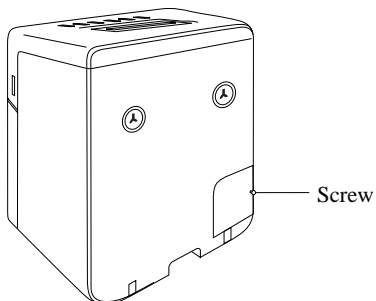

- 1** Unscrew the screw that holds the lid of the battery compartment in the lower right-hand corner of the back of the unit.

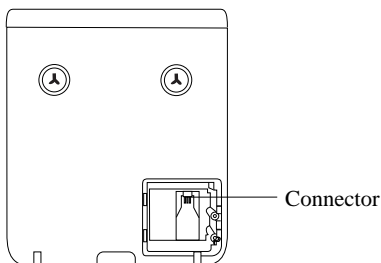

- 2** Insert the battery connector into the compartment connector to install the battery.

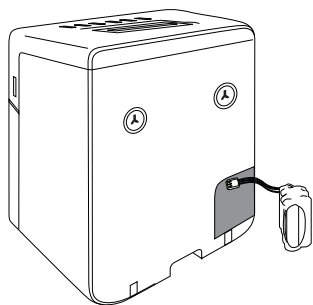

- 3** Hook the lid to close, and secure it with the screw.

Use only the originally offered Ni-Cd Battery.

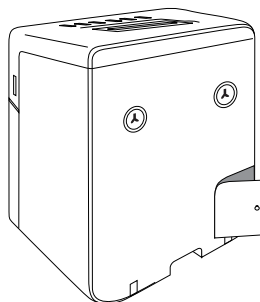

9. SPECIFICATIONS

Clock display	Monthly accuracy $\pm 15s$ (at ordinary temperature)
Calendar	Year up to 2096. Automatically adjusted to leap years, 31-day months and months with thirty or fewer days, and the days of the week.
Printing system	Dot matrix in black and red
Card mechanism	Automatic pull and eject, automatic judgment of face and back
Power failure compensation	Five years of cumulative power failure hours after the date of shipment
Print at power failure	Special Ni-Cd battery, 100-time printing or 24 hours (option)
Time program	Switching between black and red printing, designation of the time for outputting an external time signal, automatic column shift.
Connection of external time signal	Connection with a time flow device (No direct voltage output!)
Operating environment	Temperature: -5° to $+45^{\circ}C$: $+23^{\circ}$ to $+113^{\circ}F$ Humidity: 20 to 80%RH, no condensation The unit operates normally at temperatures of $5^{\circ}C$ or below, but the print density, reaction of the liquid crystal display, and the number of prints at power failure are inferior to those at normal temperature operation.
Dimensions	7.87" (w) x 10.1" (h) x 5.94" (d) 200 (w) x 257 (h) x 151 (d) mm
Weight	Approx. 5.5lbs 2.5kg
Power supply	120VAC 230VAC (220-240VAC)
Power consumption	120VAC 50/60Hz 0.2A 230VAC 50/60Hz 0.12A 220-240VAC 50/60Hz 0.12A

Machine Noise Information Ordinance 3. GSGV, January 18, 1991:

The sound pressure level at the operator position is equal to or less than 70 dB (A) according to ISO 7779.

Replace battery with TOSHIBA, part No. CR2450THC only.

Use of another battery may present a risk of fire or explosion.

10. TIME CARD SPECIFICATIONS

Note : Recommended paper thickness : $0.45 \pm 0.05\text{mm}$
 : Card style may vary.

(1) Monthly Card

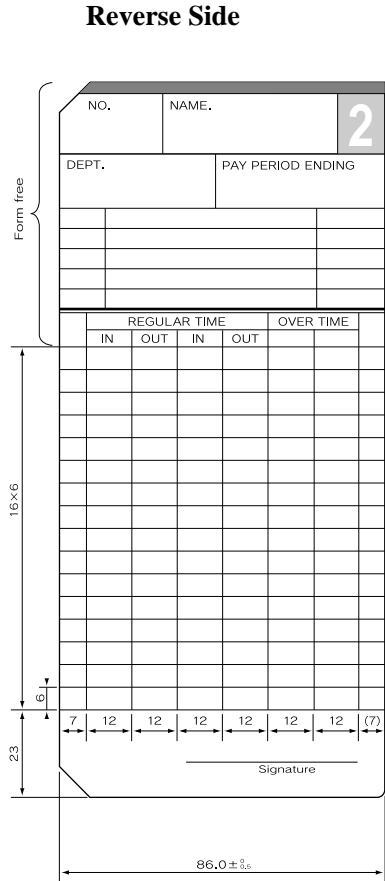
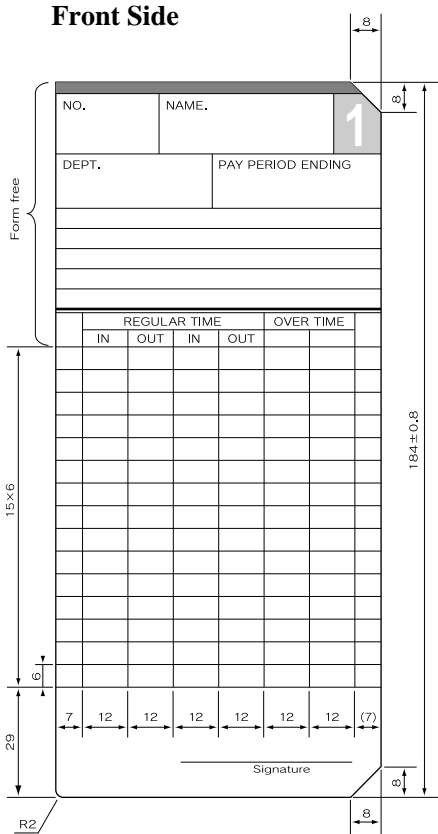

(2) Weekly Card

The diagram shows a weekly time card with the following layout and dimensions:

- Top Section:** Fields for NO., NAME., SECT., and DEP.
- TIME CARD:** A large central area for recording time.
- Year and Month:** Fields for Year: and Month: located below the TIME CARD.
- Grid:** A grid for recording time, divided into three columns: MORNING, AFTERNOON, and OVER TIME. Each column has sub-columns for IN and OUT.
- Dimensions:**
 - Total height: 184 ± 0.8
 - Top section height: 35
 - TIME CARD height: 7×6
 - Year and Month section height: 6
 - Grid height: 14×6
 - Bottom section height: 6
 - Bottom section width: 86.0 ± 0.8
 - Grid width: 6×12
 - Bottom section width: 7 , 12 , 12 , 12 , 12 , 12 , 12 , 12 , (7)
 - Bottom section width: 6×12
 - Bottom section width: 86.0 ± 0.8
- Label:** W-7

(3) Bi-Weekly Card

The diagram shows a bi-weekly time card with the following layout and dimensions:

- Top Section:** Fields for NO., NAME., SECT., and DEP.
- TIME CARD:** A large central area for recording time.
- Year and Month:** Fields for Year: and Month: located below the TIME CARD.
- Grid:** A grid for recording time, divided into three columns: MORNING, AFTERNOON, and OVER TIME. Each column has sub-columns for IN and OUT.
- Dimensions:**
 - Total height: 184 ± 0.8
 - Top section height: 35
 - TIME CARD height: 14×6
 - Year and Month section height: 6
 - Grid height: 14×6
 - Bottom section height: 6
 - Bottom section width: 86.0 ± 0.8
 - Grid width: 6×12
 - Bottom section width: 7 , 12 , 12 , 12 , 12 , 12 , 12 , 12 , (7)
 - Bottom section width: 6×12
 - Bottom section width: 86.0 ± 0.8
- Label:** W-14



recycled paper

 **Simplex**

Printed in Japan

1406-9806